



**ECO
LIGHT**
INDUSTRIAL LED

**LED
INDUSTRIAL
FLOOD
LIGHT**

LEDIFL19-55AC

ROBUST INDUSTRIAL LED FLOOD LIGHTS – 55W

The LEDIFL19-55AC is a robust & compact floodlight delivering great lumen output and efficiency and is a trusted member of our industrial floodlight range.

This is an IP65 rated fitting that includes LM6 aluminium housing and dual layer anti-corrosion powder coat finish so can be relied upon in the harshest of conditions.

This is an ideal replacement to a 500W halogen as it delivers a massive ten-fold power saving and removes ongoing maintenance concerns when compared directly.



TECHNICAL SPECIFICATIONS

Fixture/Part No.	LEDIFL19-55AC
Total Power	55W
LED Power	50W
LED Lumens	5000lm
Fixture Lumens	4750lm
LED Lighting Efficiency	>90%
Colour Temperature	5700K
Colour Rendering (Ra)	>70
IP Rating	IP65
Life Span	50,000hrs
Eco-friendly	ROHS Compliant
Operating Temperature	-30°C to 45°C
Weight	3.75kg
Beam Angle	90°
Size	Diameter 256mm, Height 176mm
Dimmable	Yes
Power Factor	>0.92
Input Voltage Range	86-265V AC
Bracket	Adjustable Aluminium with Black Powder Coating
Power Cable	3 core, 1.5m length
Powder Coating	Anti-corrosion Black
Aluminium Properties	LM6 - Si: 13%, Cu: 0.6%, Mn: 0.6%, Fe: 1.2%, Zn: 0.3%, Al: 84.3%

**ECO
LIGHT**
www.ecolight.co.nz

PRODUCT IMAGES

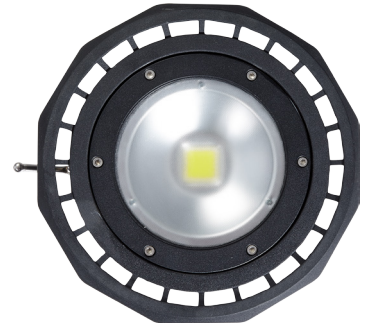

DIMENSIONS

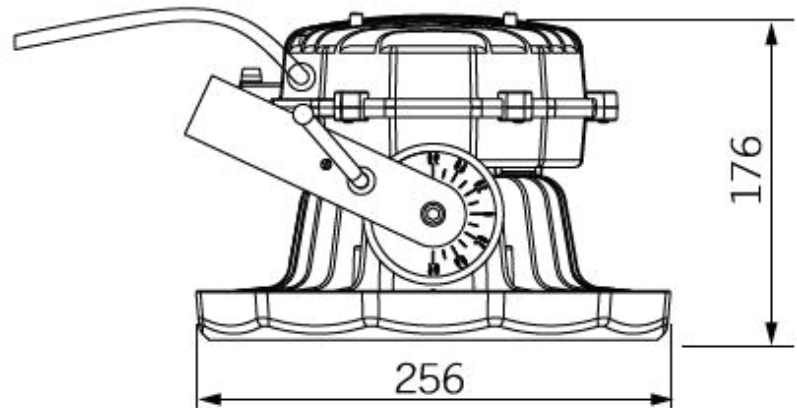
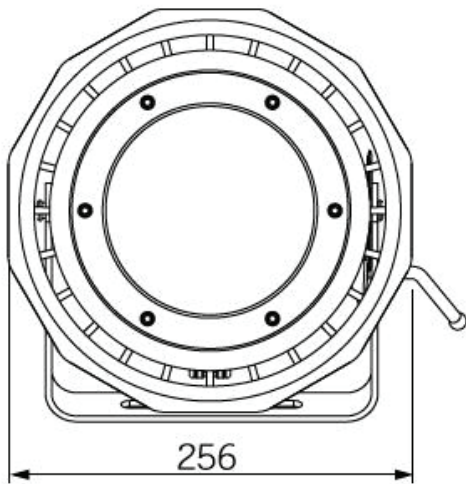

PHOTOMETRICS

Light Distribution

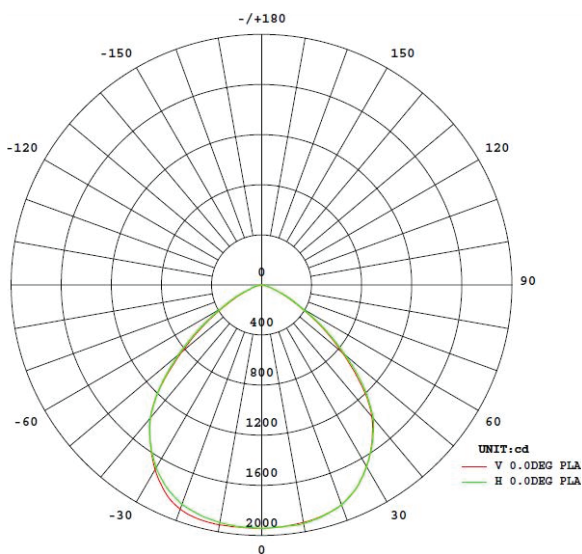

ISO Candela Diagram

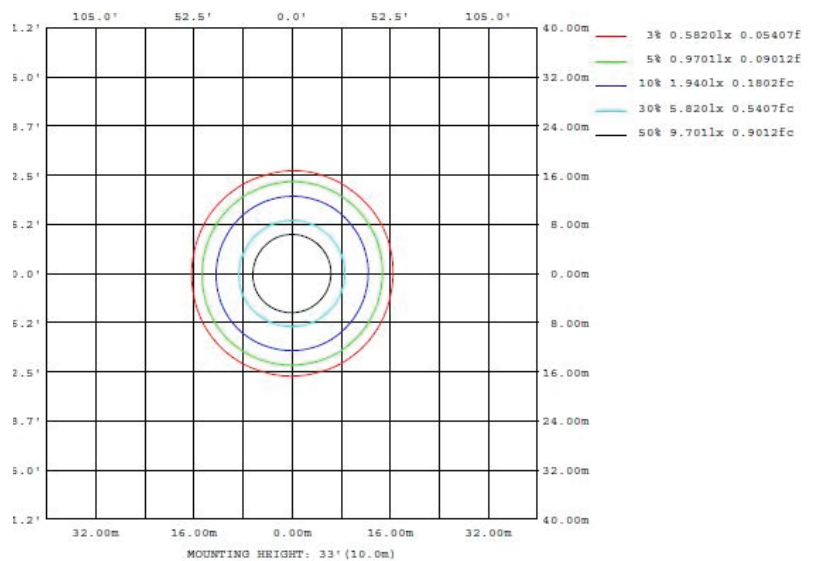

78 Cryers Road
 East Tamaki
 Auckland.
 NEW ZEALAND
 phone: 64 9 272 5619